

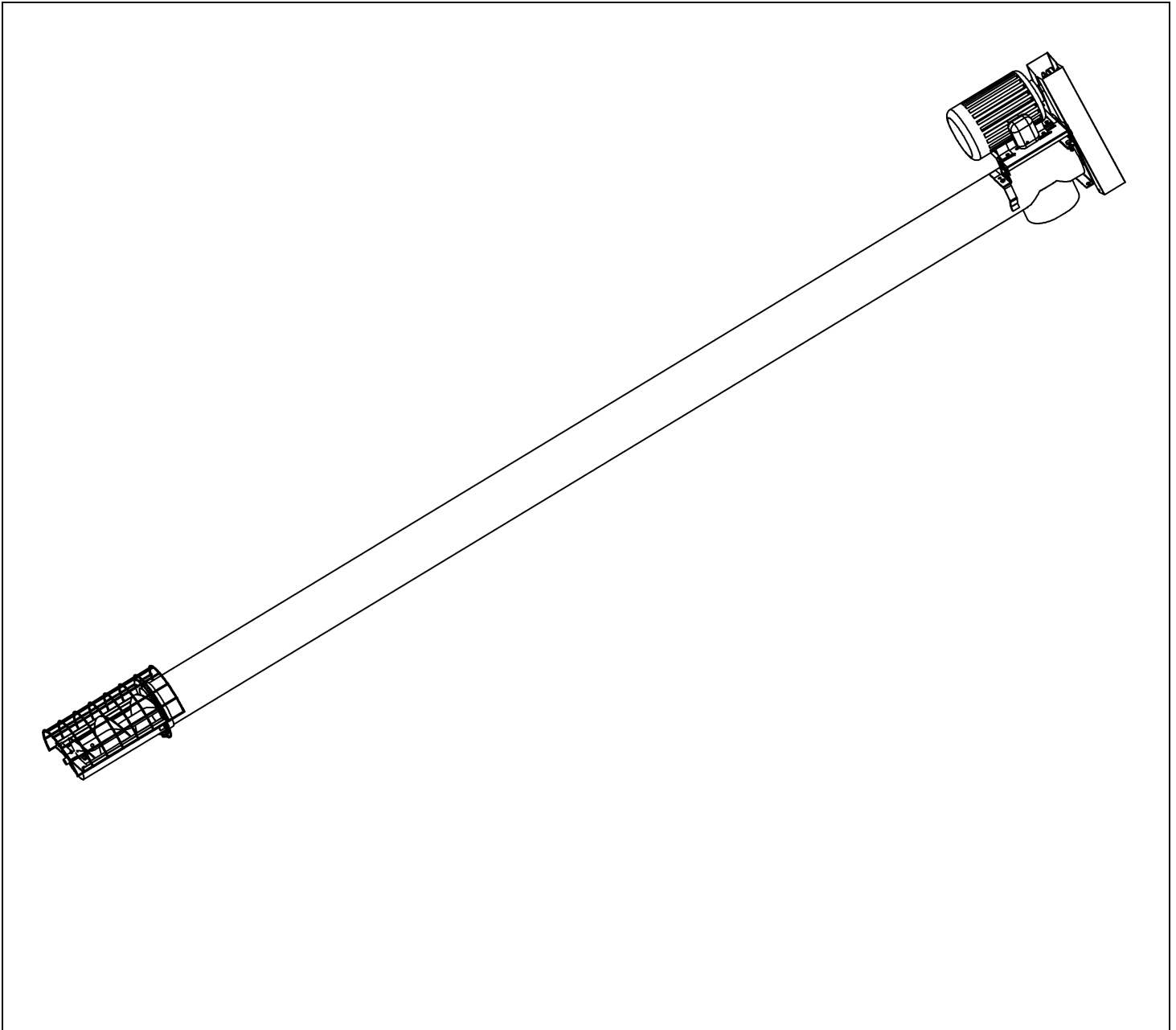

GRAIN AUGERS

UTILITY

ASSEMBLY & OPERATION MANUAL



Read this manual before using product. Failure to follow instructions and safety precautions can result in serious injury, death, or property damage. Keep manual for future reference.

Part Number: 30263 R1

Revised: 26/4/10

TABLE OF CONTENTS

1. Introduction	5
2. Safety First.....	7
2.1. General Safety	8
2.2. Assembly Safety.....	9
2.3. Operation Safety	9
2.4. Maintenance Safety.....	9
2.5. Electric Motor Safety	10
2.6. Safety Decal Locations.....	10
2.6.1. Decal Installation	10
2.6.2. Decal Locations	10
3. Assembly	13
3.1. Tube / Flight Extensions.....	13
3.2. Intake / Optional Feed Control	14
3.3. Head Drive	15
3.4. Motor Mount	15
3.5. Electric Motor Installation / Alignment	16
3.6. Bushing (Optional).....	18
3.7. Hopper (Optional).....	18
3.8. Site Installation Procedures.....	19
3.9. Trussing (Optional).....	20
4. Operation & Maintenance.....	23
4.1. Pre-Operational Checklist	23
4.2. Auger Drive and Lockout	23
4.3. Operating Procedures	23
4.3.1. Start-Up & Break-In	23
4.3.2. Operating with a Full Load.....	24
4.3.3. Shutdown.....	25
4.4. Maintenance.....	26
4.4.1. General Maintenance Procedure.....	26
5. Troubleshooting	27

1. Introduction

Congratulations. As the new owner of a grain auger, you will be working with equipment designed to complement and improve your farming operation. Before using this auger, please read this manual and all safety labels and familiarize yourself with the various features of the machine and the necessary precautions for efficient and safe operation.

In addition, anyone using this auger is required to comply with all safety precautions in this manual and in safety labels attached to the auger. A sign-off form is supplied on the inside front cover to record your safety reviews.

Thank you.

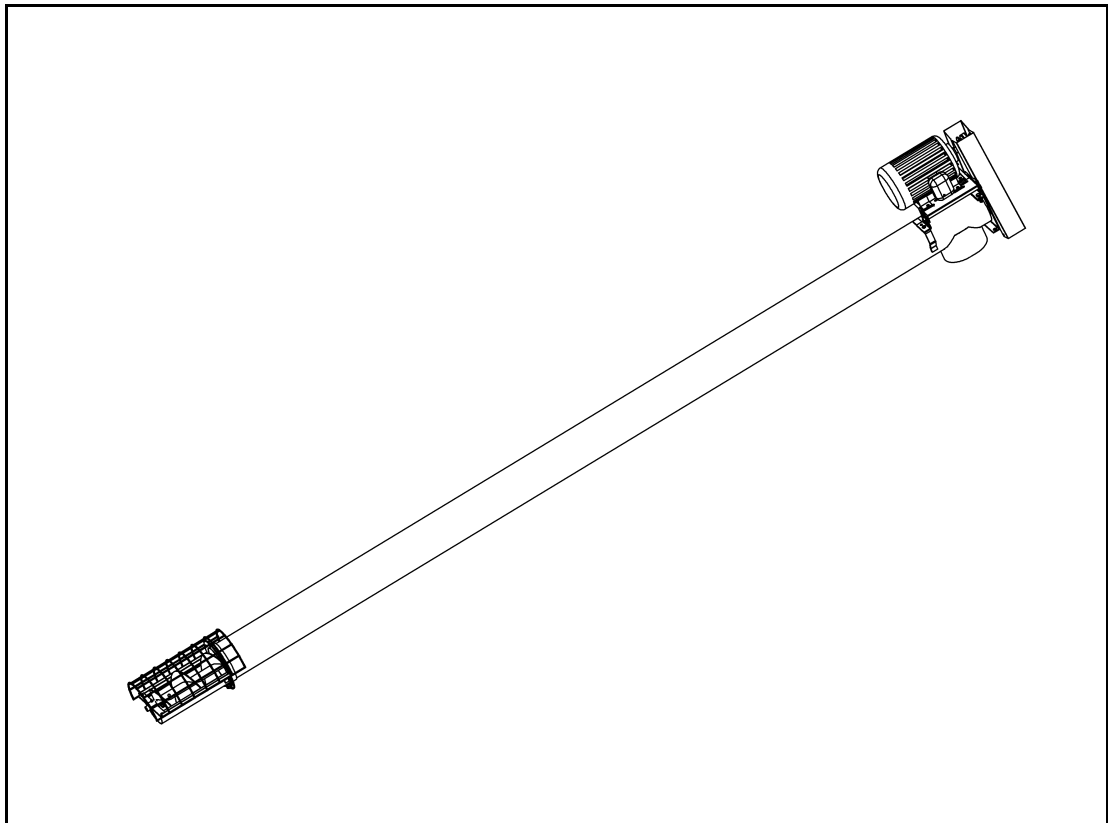

Serial Number:	
*Serial number is located at top of tube.	

2. Safety First



The Safety Alert symbol to the left identifies important safety messages on the product and in the manual. When you see this symbol, be alert to the possibility of personal injury or death. Follow the instructions in the safety messages. Why is SAFETY important to you?

Three big reasons:

- Accidents disable and kill.
- Accidents cost.
- Accidents can be avoided.

SIGNAL WORDS

Note the use of the signal words **DANGER**, **WARNING**, **CAUTION**, and **NOTICE** with the safety messages. The appropriate signal word for each message has been selected using the definitions below as a guideline.

The Safety Alert symbol means ATTENTION, BE ALERT!, YOUR SAFETY IS INVOLVED.

DANGER



Indicates an imminently hazardous situation that, if not avoided, will result in serious injury or death.

WARNING



Indicates a hazardous situation that, if not avoided, could result in serious injury or death.

CAUTION



Indicates a hazardous situation that, if not avoided, may result in minor or moderate injury.

NOTICE

Indicates a potentially hazardous situation that, if not avoided, may result in property damage.

2.1. GENERAL SAFETY

Important: *The general safety section includes instructions that apply to all safety practices. Any instructions specific to a certain safety practice (e.g., assembly safety), can be found in the appropriate section. Always read the complete instructional sections and not just these safety summaries before doing anything with the equipment.*

YOU are responsible for the **SAFE** use and maintenance of your equipment. **YOU** must ensure that you and anyone else who is going to work around the equipment understands all procedures and related **SAFETY** information contained in this manual.

Remember, **YOU** are the key to safety. Good safety practices not only protect you, but also the people around you. Make these practices a working part of your safety program.

- It is the equipment owner and the operator's responsibility to read and understand **ALL** safety instructions, safety decals, and manuals and follow them before assembling, operating, or maintaining the equipment. All accidents can be avoided.
- Equipment owners must give instructions and review the information initially and annually with all personnel before allowing them to operate this product. Untrained users/operators expose themselves and bystanders to possible serious injury or death.
- Use this equipment for its intended purposes only.
- Do not modify the equipment in any way. Unauthorized modification may impair the function and/or safety, and could affect the life of the equipment. Any modification to the equipment voids the warranty.
- Do not allow children, spectators, or bystanders within the work area.
- Have a first-aid kit available for use should the need arise, and know how to use it.
- Provide a fire extinguisher for use in case of an accident. Store in a highly visible place.
- Wear appropriate protective gear. This list includes, but is not limited to:
 - a hard hat
 - gloves
 - protective shoes with slip-resistant soles
 - protective goggles
 - hearing protection
- For Powered Equipment: before servicing, adjusting, or repairing powered equipment, unplug, place all controls in neutral or off position, stop the engine or motor, remove ignition key or lock out power source, and wait for all moving parts to stop.



- Follow good shop practices:
 - keep service area clean and dry
 - be sure electrical outlets and tools are properly grounded
 - use adequate light for the job at hand
 - Think SAFETY! Work SAFELY!



2.2. ASSEMBLY SAFETY

- Read through the instructions to get to know the sub-assemblies and hardware that make up the equipment.
- Do not take chances with safety. The components are large, heavy, and can be hard to handle. Always use the proper tools, stands, jacks, and hoists for the job.
- Always have 2 or more people assembling the equipment. Because of the weight, do not attempt assembly alone.

2.3. OPERATION SAFETY

- Have another person nearby who can shut down the auger in case of accident. Always work with a second person around augers.
- Do not operate with any of the safety guards removed.
- Keep body, hair, and clothing away from moving parts. Stay away from intake during operation.
- Augers are not insulated. Keep away from electrical lines. Electrocutation can occur without direct contact.
- Ensure that auger is empty before moving.
- Inspect auger supports on a daily basis.
- Support auger securely to prevent upending or upsetting.

2.4. MAINTENANCE SAFETY

- Shut down and lock out all power before attempting maintenance of any kind. If applicable, disconnect PTO driveline from tractor or hydraulic hoses on units with hydraulic drive hoppers.
- After maintenance is complete, replace and secure all safety guards and safety devices, and if applicable, service doors and cleanout covers.
- Use only genuine Applegate replacement parts or equivalent. Replacement parts such as intake guards, pulley guards, PTO driveline shields, winches, and lift cables must meet ASAE standards or serious injury may result. Use of unauthorized parts will void warranty. If in doubt, contact Wheatheart or your Wheatheart dealer. Do not modify any auger components.

2.5. ELECTRIC MOTOR SAFETY

- Inspect the drive belts before using auger. Replace if frayed or damaged.
- Do not grab or touch drive belts during operation for any reason.
- Remember to ground electric motor before using auger.

2.6. SAFETY DECAL LOCATIONS

- Keep safety decals clean and legible at all times.
- Replace safety decals that are missing or have become illegible. See decal location figures below.
- Replaced parts must display the same decal(s) as the original part.
- Safety decals are available from your distributor, dealer, or factory.

2.6.1. DECAL INSTALLATION

1. Decal area must be clean and dry, with a temperature above 10°C (50°F).
2. Decide on the exact position before you remove the backing paper.
3. Align the decal over the specified area and carefully press the small portion with the exposed sticky backing in place.
4. Slowly peel back the remaining paper and carefully smooth the remaining portion of the decal in place.
5. Small air pockets can be pierced with a pin and smoothed out using the sign backing paper.

2.6.2. DECAL LOCATIONS

Replicas of the safety decals that are attached to the equipment are shown in the figure(s) that follow. Good safety requires that you familiarize yourself with the various safety decals and the areas or particular functions that the decals apply to as well as the safety precautions that must be taken to avoid serious, injury, death, or damage.

** Applegate reserves the right to update safety decals without notice. Safety decals may not be exactly as shown.*

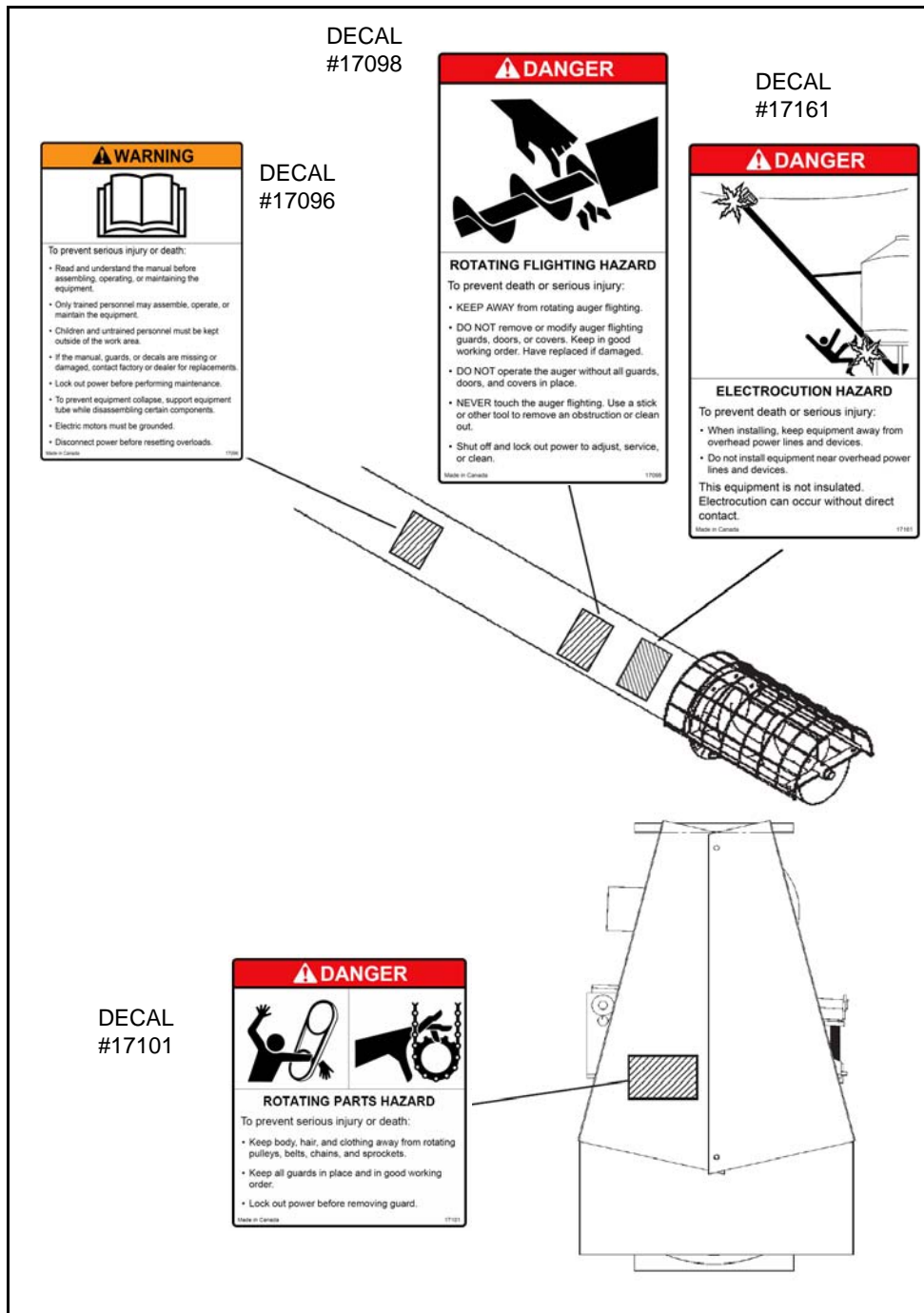

Figure 2.1 Safety Decal Locations

3. Assembly

Warning: Before continuing, please reread the safety information relevant to this section at the beginning of this manual. Failure to follow the safety instructions can result in serious injury, death, or property damage.

Arrange all parts of your auger for easy access. Carry out assembly in a large open area with a level surface.

Important: *Always have 2 or more people assembling the equipment. Because of the weight, do not attempt assembly alone.*

➔ *The following assembly procedure covers all required steps for the utility auger, including those considered to be optional. Instructions which may not apply to your particular auger will be indicated with an arrow.*

3.1. TUBE / FLIGHT EXTENSIONS

1. Position tube sections. Align tube sections on a flat surface or on a series of benches.

WARNING	
	<p>Do not drop. Damage to equipment or serious personal injury will result.</p>

- ➔ 2. For 6" and 7" diameter augers, screw lower flight into threaded connector on upper flight using 2 pipe wrenches until flight ends butt together and flighting spiral matches up. Tighten set screw (2.).

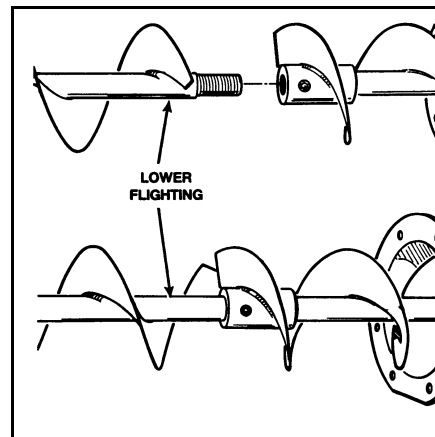

Figure 3.1 Lower Flighting (6" & 7")

- ➔ 3. For 8", 10", and 13" diameter augers, slide lower flight shaft into upper flight shaft until flight ends butt together and flighting spiral matches up. Secure with two 7/16" x 2-1/4" bolts and locknuts on the 8" auger, two 1/2" x 2-3/4" bolts and locknuts on the 10" auger, or two 5/8" x 4-1/2" bolts and locknuts for 13" auger (3.).
4. Slide tube sections together and fasten with 7/16" x 1" (7/16" x 1-1/4" for 13" auger) bolts and locknuts.
5. For additional sections, repeat steps 1 and 2.

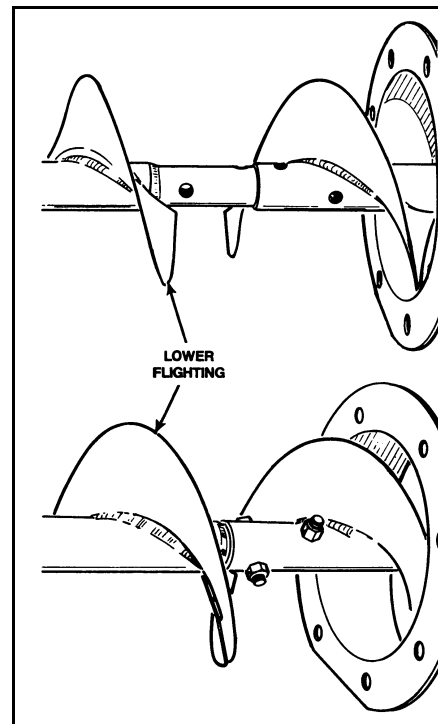

Figure 3.2 Lower Flighting
(8", 10" & 13")

3.2. INTAKE / OPTIONAL FEED CONTROL

1. Attach intake to lower end of auger tube with four 7/16" x 1" (7/16" x 1-1/4" for 13" auger) bolts and locknuts (except the 6" auger which requires three bolts and locknuts) (Figure 3.3).

Note: *When the auger may run empty for more than a few minutes, a bushing is recommended on the lower flight; see Section 3.6. for installation procedure.*

Note: *To replace intake assembly with hopper assembly, or to install hopper assembly, see Section 3.7.*

1. **To install optional feed control:**
 - a. Attach the feed control tube clamp (Figure 3.3) to auger tube with two 7/16" x 1" bolts and locknuts. Do not tighten at this time.
 - b. Thread the control handle through the tube clamp and place the feed control slide beneath the intake guard.
 - c. Seat tube clamp against stop on control handle and lock into place with the T-bolt on the clamp.
 - d. Slide feed control assembly down until lower end is a minimum of 1/2" past the lower end of the tube. Tighten the tube clamp.

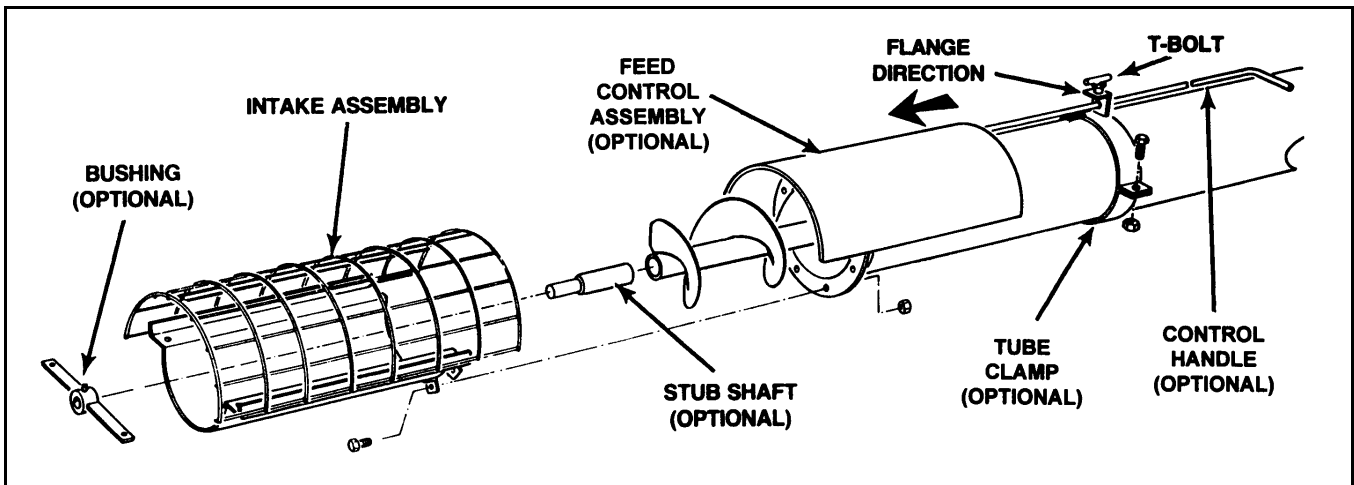

Figure 3.3 Intake/Optional Feed Control

3.3. HEAD DRIVE

1. Remove dirt and paint from upper end of flight shaft.
2. Install the woodruff key provided (or a square key) and slide the larger pulley onto the flight shaft with the hub facing away from the auger but DO NOT tighten set screws at this time (see Table 3.1 on page 17 for proper pulley size).

3.4. MOTOR MOUNT

1. Install front mount plate onto head plate using two 1/2" x 1 1/2" bolts, locknuts, and 1/2" flat washers, as shown in Figure 3.4. Tighten securely.
2. Place 5/8" adjust bolt through available hole in front mount plate and secure with two 5/8" hex nuts (one top, one bottom). Leave adjust bolt loose to allow for later adjustment.

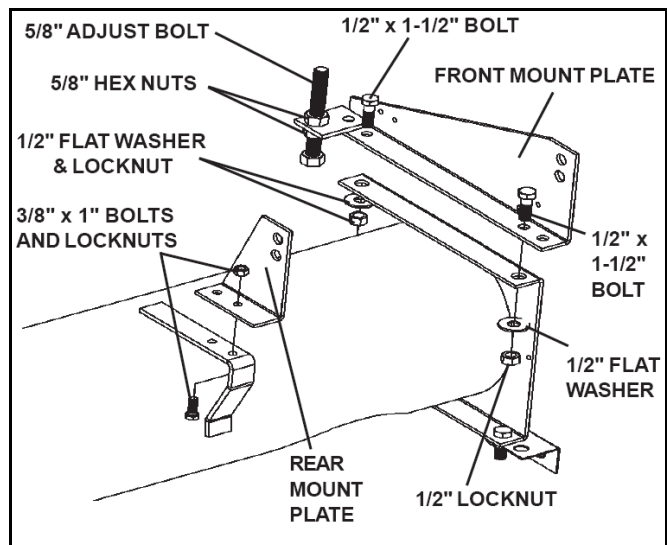

Figure 3.4 Head Plate

Note: The 5/8" nuts and adjust bolt are used to adjust belt tension (Section 3.5.).

3. Assemble rear mount plate onto tube bracket as shown in Figure 3.4. Using two 3/8" x 1" bolts and locknuts, tighten securely.

4. Place motor mount assembly in between the two mount plates, and insert hinge rod as shown in Figure 3.5. Secure hinge rod with a 1/8" x 1-1/2" cotter pin.

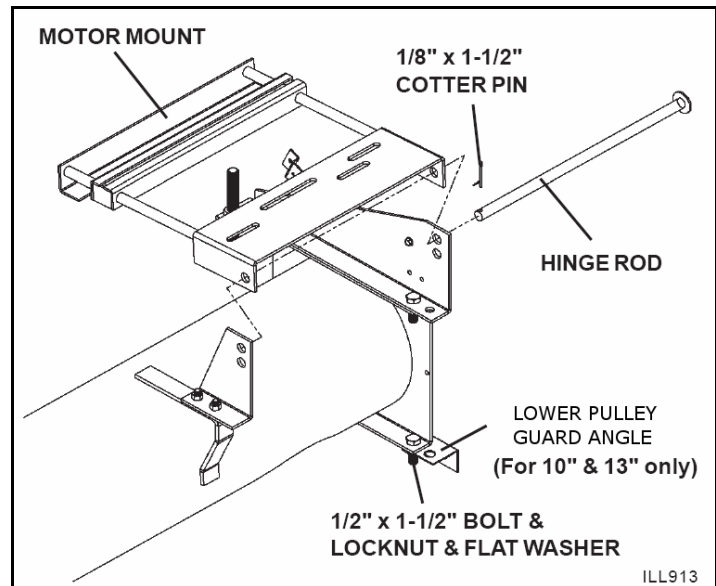

Figure 3.5

- ➔ 5. For 10" and 13" augers, attach lower pulley guard angle to the head plate with two 1/2" x 1-1/2" bolts and locknuts and 1/2" flat washers (Figure 3.5). Tighten securely.

3.5. ELECTRIC MOTOR INSTALLATION / ALIGNMENT

1. Place electric motor (see Table 3.2 on page 17 for proper horsepower requirements) onto motor mount and secure. Motor shaft must be parallel to and centered on discharge tube before tightening adjust bolt.

When using an electric motor:

- The motor and controls should be installed by a qualified electrician in accordance with all local and national codes.
- Incorporate a magnetic starter to protect the motor.
- The motor must have a manual reset button.
- Locate reset and starter controls so that the operator has full view of the entire operation.
- Locate main power disconnect switch within reach from ground level to permit ready access in case of an emergency.
- A main power disconnect switch capable of being locked (in the off position only) must be provided.

Table 3.1 Pulley Sizes / Combinations^a

Utility Auger Size	Recommended Sizes		
	Auger Pulley	Motor Pulley	*Flight Speed (rpm)
6"/7" Utility	12.7"	3 1/2"	475
	12.7"	4"	543
8" Utility	12.7"	3 1/4"	440
	12.7"	3 1/2"	475
10" Utility	15"	3 1/4"	375
	15"	3 1/2"	402
13" Utility	16"	3 1/4"	350
	16"	3 1/2"	378

To determine flight speed (rpm):^b

Divide the speed (rpm) of the motor by the outside diameter of the large auger pulley, then multiply by the outside diameter of the small motor pulley.
Example: 1725 (rpm) ÷ 15" x 3.5" = 402 rpm

- a. Speed calculated using a 1725 rpm electric motor.
- b. If a slower flight speed is desired, install a smaller motor pulley.

Table 3.2 Horsepower Requirements^a

Length	6"	7"	8"	10"	13"
16'-21'	1½-2	2-3	3	3-5	10
26'-31'	3	3-5	5	5-7½	15
36'-41'	3-5	5-7½	5-7½	7½-10	20
46'-51'	5	7½	7½-10	10-15	N/A
56'-61'	7½	7½-10	10	15-20	N/A

- a. Approximate electric motor horsepower requirements under normal conditions.
When augering full tube of high moisture grain, additional horsepower will be needed.

2. Slide drive pulley onto motor shaft (see Table 3.1 for suggested sizes). Insert the appropriate size of square key. Do not tighten set screw until belts are aligned.

➡ We recommend using the 3 belt and triple groove pulley option on all 13" augers.

3. Place belts on pulleys. Adjust the 5/8" adjust bolt on front mount plate until the belts have the proper tension with about a 1/8" deflection.

Note: The correct operating tension is the lowest tension at which the belts will not slip under peak load conditions.

4. Align the two pulleys (use a straight edge). Once belts are aligned and under tension, lock the 5/8" hex nuts and tighten pulley set screws.

Note: Once all bolts and set screws are tightened, re-check alignment. Proper alignment will prolong belt life.

5. For 6"/7"/8" augers, assemble the adjustable two-piece pulley guard with two 1/4" x 1/2" bolts and washer locknuts. For 10"/13" augers, assemble the adjustable three-piece pulley guard with four 1/4" x 1/2" bolts and washer locknuts (see Figure 3.6).

Note: A guard extension is required on all powerheads using a 15" pulley.

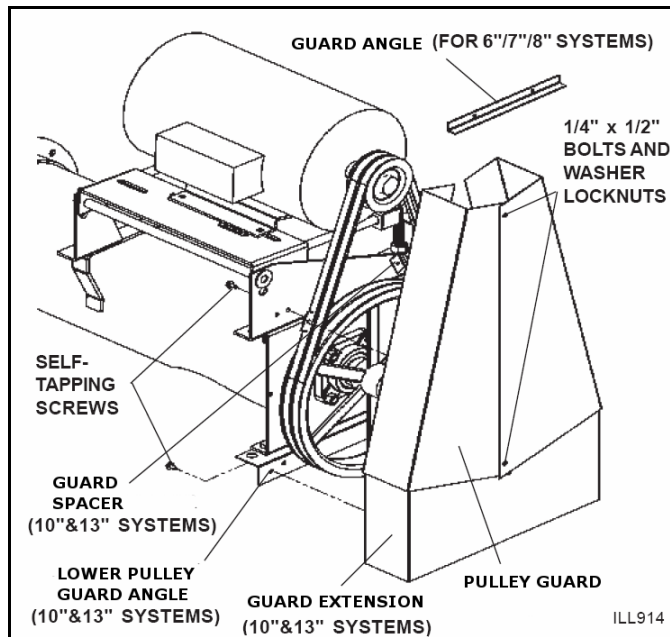

Figure 3.6 Pulley Guard

6. For **6"/7"/8" augers**, attach the pulley guard to the front mount plate and the end plate with four self-tapping screws. The guard is mounted to front mount plate using a single guard angle attached with self-tapping screws. For **10"/13" augers**, attach the pulley guard to the lower pulley guard angle and the end plate with four self-tapping screws. The guard is mounted to the end plate using two guard spacers attached with self-tapping screws.

3.6. BUSHING (OPTIONAL)

In order to provide additional support for the lower flighting, an optional support bushing package is available. See Figure 3.3. To install:

1. Insert the stub shaft (supplied with the bushing) into the lower flighting shaft and secure with a set screw (on the 6" and 7" augers), or a bolt and locknut (on the 8", 10", and 13" augers).
 - The 8" auger requires a 7/16" x 2-1/4" bolt and locknut
 - The 10" auger requires a 1/2" x 2-3/4" bolt and locknut
 - The 13" auger requires a 5/8" x 4-1/2" bolt and locknut.

Note: *Maintain a 1/4" to 1/2" clearance should between the flighting and the bushing.*

2. Slide the bushing onto the stub shaft and attach to the intake with two 7/16" x 1" bolts and locknuts. Ensure that the grease fitting is on top of the bushing after assembly.

3.7. HOPPER (OPTIONAL)

See Figure 3.7.

If the optional hopper assembly is being installed in place of the intake assembly, proceed as follows:

1. Insert the stub shaft (supplied with the bushing) into the lower flighting shaft and secure with a set screw (on the 6" and 7" augers), or a bolt and locknut (on the 8", 10", and 13" augers).
 - 8" auger requires a 7/16" x 2-1/4" bolt and locknut
 - 10" auger requires a 1/2" x 2-3/4" bolt and locknut
 - 13" auger requires a 5/8" x 4-1/2" bolt and locknut

Note: *If feed control slide is mounted on the auger, it must be removed before installing hopper.*

2. Place hopper over lower flighting, ensuring that the stub shaft is properly seated in the hopper bearing.
3. Attach hopper assembly to lower end of auger tube with four 7/16" x 1" (7/16" x 1 1/4" for 13" auger) bolts and locknuts (except the 6", which requires three bolts and locknuts).

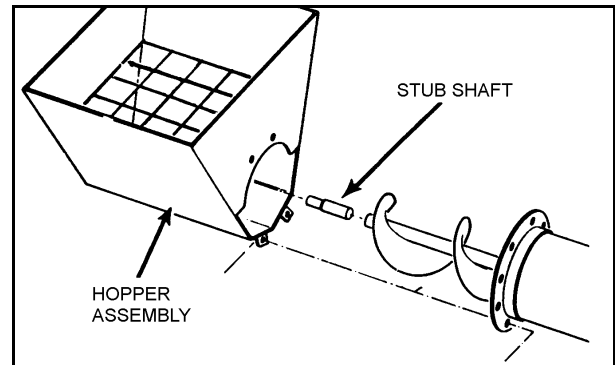



Figure 3.7

3.8. SITE INSTALLATION PROCEDURES

Site installation procedures for any Utility Auger varies depending on auger length, location, and intended use. Because of these variables, use the following instructions as a guide only. The installer is responsible for properly braced and/or supporting the auger before operating, with the primary concern being on safety. As a general rule, we suggest the following:

1. Check that all bolts are tightened as per instructions.
2. Ensure that all safety devices are in place and secure.
3. Use a safe lifting device such as a front-end loader or crane to raise and position the auger, ensuring that the entire area in line of travel is clear of any obstructions or electrical wires.

DANGER	
	<p>Keep equipment away from overhead power lines and obstructions.</p> <p>Machine is not insulated and electrocution may occur without direct contact.</p> <p>Failure to keep away will result in serious injury or death.</p>

Once auger is in position:

1. Where possible, secure both the intake and discharge ends of the auger to prevent upending or upsetting from factors such as high wind, vibration, or grain weight shift.

2. If auger is used in a free standing position, it must be braced and/or supported to prevent upending or upsetting from factors such as high wind, vibration, or grain weight shift.

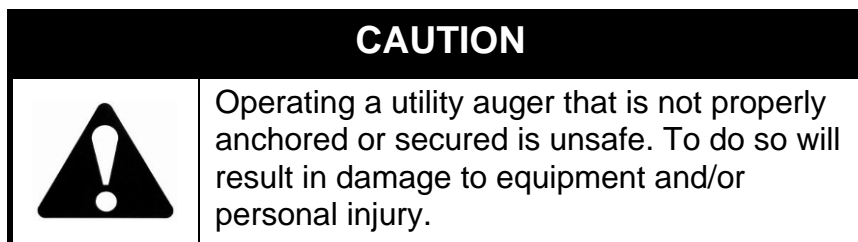

Note: *Longer utility augers may require trussing or additional bracing. Cable truss kits and tube clamps for the attachment of bracing are available from Westfield as options. See Section 3.9. for trussing installation.*

3. Ensure that On/Off switches are conveniently located and marked in case of emergency.

3.9. TRUSSING (OPTIONAL)

See Figure 3.8.

If trussing is required on your auger, 30' and 40' truss kits are available from Westfield as an option. Before purchasing, determine the unsupported length of auger in order to obtain the proper kit. The following procedure is a guide for installing the trussing, but can be changed if circumstances warrant it. To install:

1. Once auger is in place and secure, determine center of unsupported length (lowest point of sag) and mount truss struts with 7/16" x 1" bolts and locknuts. Do not tighten.
2. Attach strut braces (Figure 3.8) with 7/16" x 1" bolts and locknuts and secure.
3. Rotate strut assembly to a 45° angle and tighten half ring bolts.
4. Mount the truss; attach angles to the truss anchor half rings with two 7/16" x 1" bolts and locknuts each.
5. Locate and mount the half ring assemblies above and below the strut assembly with 7/16" x 1" bolts and locknuts. Do not tighten at this time.

➔ *The distance for mounting the half ring assemblies is limited by the length of cable in your kit. Maximum distance for the 30' kit is approximately 28'. Maximum for the 40' kit is 38'.*

6. Put cable clamps in place on the strut assembly and place the eyebolts into the truss attach angles.
7. String the cable through the cable clamps, centre the cable, and tighten the cable clamps.

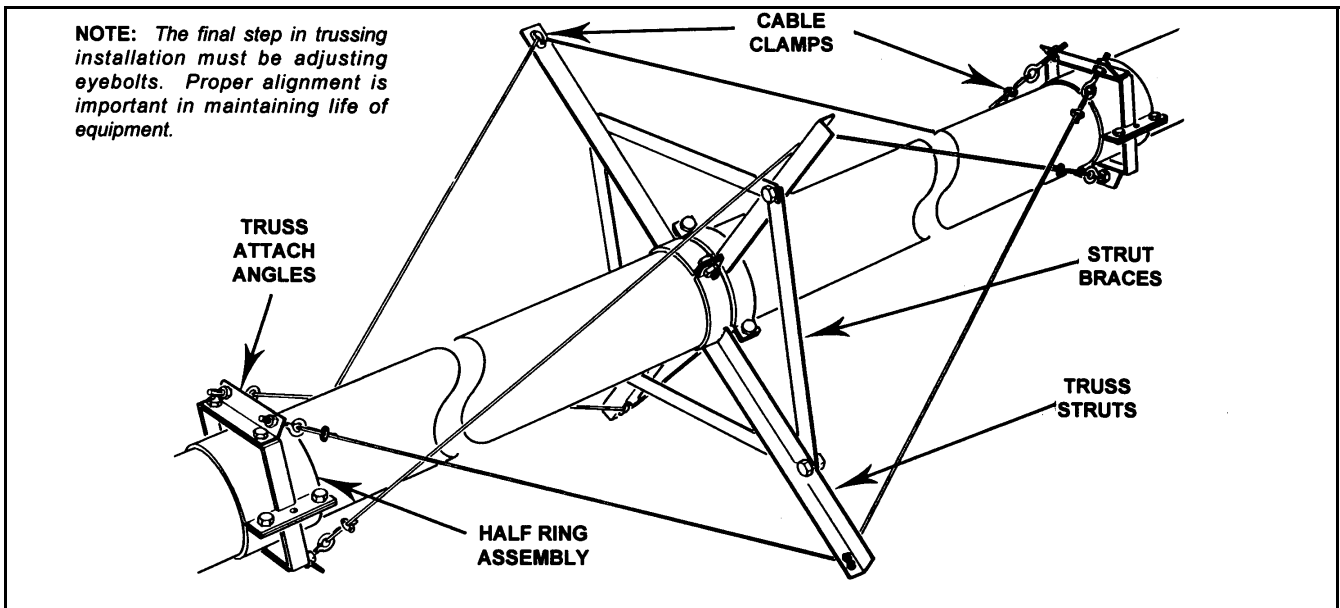

Figure 3.8

8. Thread the cable through the eyebolts (upper cables to lower eyebolts), pull snug, and install cable clamps.
9. Once cables are in place, tighten bolts on the half ring assemblies.
10. Tighten eyebolts until sag is eliminated.

4. Operation & Maintenance

Warning: Before continuing, please reread the safety information relevant to this section at the beginning of this manual. Failure to follow the safety instructions can result in serious injury, death, or property damage.

Operators must observe safety procedures at all times and follow the pre-operational checklist before each start-up.

4.1. PRE-OPERATIONAL CHECKLIST

Before operating auger each time, the operator must confirm the following:

- All fasteners are secure as per assembly instructions.
- Drive belt(s) are not frayed or damaged.
- Drive belt(s) are properly adjusted and aligned.
- Tube alignment is reasonably straight.
- Intake area and discharge spout are free of obstructions.
- Proper maintenance has been performed.
- Inspect auger supports frequently.

4.2. AUGER DRIVE AND LOCKOUT

Drive Type	Before Operation	Lockout
Electric Motor	Before starting motor, ensure <ul style="list-style-type: none"> • motor is properly grounded • pulley shields are in place and secure 	The electric motor should be equipped with a main power disconnect switch capable of being locked in the off-position only. The switch should be in the locked position during shutdown or whenever maintenance is performed on the auger. <ul style="list-style-type: none"> • If reset is required, disconnect all power before resetting motor.

4.3. OPERATING PROCEDURES

4.3.1. START-UP & BREAK-IN

1. Complete the checklist at the beginning of this chapter. If everything is satisfactory, prepare for a 30 minute operation at half speed.

2. Correctly position portable grain hopper and secure to auger with both straps (where applicable).

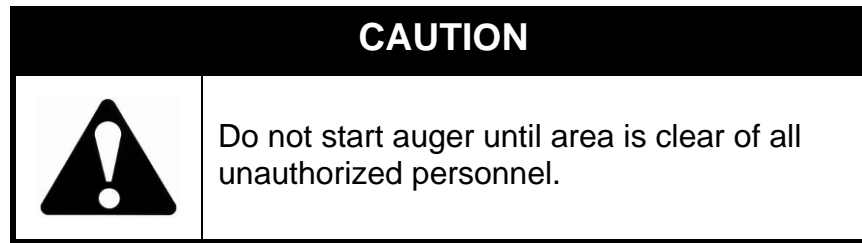

3. Start electric motor, then feed grain to auger.

Important: *When starting auger for the first time, be prepared for an emergency shutdown in case of excessive vibration or noise. Note that auger may run rough until tube is polished.*

4. Upon completion of initial run, shutdown auger. See “Shutdown” on page 25.
5. Lock out motor and conduct a complete inspection of auger following the checklist at the beginning of this chapter.

After the initial start-up and inspection, shut down the auger and inspect it at least three times during the first 10 hours of operation.

Keep operation of empty auger to a minimum, as this results in excessive wear.

Once auger is broken in, the checklist should be a part of the daily routine before operating auger.

4.3.2. OPERATING WITH A FULL LOAD

1. When operating the auger, always work with a second person in a position to monitor the operation and initiate a shutdown in case of emergency.
2. Monitor the auger during operation for abnormal noises or vibrations.
3. Shut off all power before making adjustments, servicing, or clearing the machine.

DANGER	
	<p>Rotating Flighting Hazard!</p> <p>To prevent death or serious injury:</p> <ul style="list-style-type: none"> • Keep away from rotating auger flighting. • Do not remove or modify auger flighting guards, doors, or covers. Keep in good working order. Have replaced if damaged. • Do not operate the auger without all guards, doors, and covers in place. • Never touch the auger flighting. Use a stick or other tool to remove an obstruction or clean out. • Shut off and lock out power to adjust, service, or clean.

USE OF GRAIN SPREADERS: Many grain spreaders cannot handle the large capacity of some augers. Some augers plug, causing damage to the flighting and other drive components. This type of damage is not covered by warranty. Hints on how to avoid this...

- Get a larger spreader, if available.
- Remove the spreader.
- Make sure spreader is turned on and operating.
- When using a flex down spout, center auger spout above spreader and do not lower auger spout into spreader.
- Suspend the spreader lower from bin ceiling leaving extra room for excess grain to flow over the spreader.

BIN LEVEL INDICATORS: These augers are fast and bins fill up quickly. A full bin will cause auger to plug, which can damage the flighting and other drive components. Installing quality grain-level indicators on your bins will allow you to monitor bin filling and help prevent damage to your auger.

4.3.3. SHUTDOWN

NORMAL SHUTDOWN:

1. Near the end of a load, decrease the flow of grain until auger is clear.
2. Once auger is clear, stop motor and lockout power (Section 4.2.).

Note: *Remember that the flighting rpm on augers equipped with electric motors is not adjustable except with a change of pulley size.*

EMERGENCY RESTART:

1. If the auger is shut down for an emergency, lock out motor before correcting problem.

- If the problem is plugging, clear as much of the grain as possible using a piece of wood, vacuum cleaner or other tool before restarting unit. **Do not use your hands.** See “Auger Drive and Lockout” on page 23.

NOTICE

Starting the auger under load may result in damage to unit. Be sure there is no blockage.

4.4. MAINTENANCE

Proper maintenance habits on the auger mean a longer life for the machine, better efficiency and safer operation. Please follow the guidelines below.

4.4.1. GENERAL MAINTENANCE PROCEDURE

Area	Maintenance Procedure	Frequency
General	While auger is in use, observe the operation checklist on page 23.	Daily
General	If for any reason a part becomes damaged, replace it immediately. If possible, lower auger to replace parts.	Regularly
Drive Belt	Check and replace if frayed or damaged. Ensure tension is correct under load (correct tension is the lowest at which the belts will not slip under peak load conditions)	Frequently
Auger Supports	Inspect (cracked welds, proper configuration of supports, bent/damaged pieces, etc.)	Frequently
Intake Bushing	If bushing is used on your auger, lubricate.	Daily
Truss Cables	Check to see that they are reasonably straight.	Regularly
Motor Cover	Protect motor from weather by covering.	During off season or when not in use.

Important: *Use only genuine Applegate replacement parts or equivalent. Replacement parts such as intake guards, pulley guards, PTO driveline shields, winches, and lift cables must meet ASAE standards or serious injury may result. Use of unauthorized parts will void warranty. If in doubt, contact Applegate or your Applegate dealer. Do not modify any auger components.*

5. Troubleshooting

Problem	Possible Cause	Remedy
Excessive noise or vibration. *Remember to follow proper break-in procedures—auger may run rough until tube is polished. If noise is extreme from outset or continuous after several loads of grade are fed, continue with troubleshooting below	Truss cables incorrectly adjusted.	Support end of auger and adjust cables so auger is flat or curves slightly upwards.
	Flighting peeled back due to plugging.	Inspect spout end of auger for flight condition. Remove and replace flight sections as necessary.
	Bent flighting sections.	Support auger and remove all flight sections. Check for straightness of flight stubs by rolling across flat concrete section. Straighten stub or replace as necessary. Take care not to bend flighting when reinstalling.
	Obstruction in tube.	Visually inspect for cloth or trash wrapped around flighting, or buildup of gum from oily crops such as flax or canola.
Drive belts jumping off pulleys.	Motor misaligned.	Ensure drive and driven pulleys are correctly aligned.
	Belts mismatched.	Check Assembly Section for correct belt sizes and only replace in pairs.
	Belt tension inadequate.	Maintain correct tension as per assembly section.
	Using a lower horsepower motor than recommended.	See Assembly Section for recommended motor sizes.
Premature wear on auger tubes.	Auger being run at low capacity or empty for extended period of time.	Frequently occurs on farms using grain wagons. Auger should not be left unattended when filling bins.
	Bent flighting.	
	Flighting allowed to wear beyond normal point of replacement.	When flighting becomes razor-thin at intake, replacement is critical. Since flight material is double thickness at welded lap joints, high spots on flight occur and can accelerate spot tube wear.



Applegate Livestock Equipment Inc.

Is a Division of Ag Growth International Inc. Group

P.O Box 151

902 South St. Rd. 32

Union City, IN 47390

phone: 800-354-9502

fax: 765-964-3529

website: www.applegatelivestockequipment.com

© Ag Growth Industries Limited Partnership 2010